

AW Math 10 - UNIT 3 – MEASUREMENT – PART 1

Assignment	Title	Work to complete	Complete
1	<i>The Metric System</i>	Part A Part B Part C Part D	
2	<i>The Imperial System</i>	Part A Part B Part C	
3	<i>Converting Measurements Between Systems</i>	Converting Measurements Between Systems	
4	<i>Metric and Imperial Estimation</i>	<i>Metric and Imperial Estimation</i>	
	Quiz 1		
5	<i>Perimeter</i>	Perimeter	
6	<i>Circumference</i>	Circumference	
7	<i>Area</i>	Area	
8	<i>More Area</i>	More Area	
9	<i>Surface Area</i>	Surface Area	
	Quiz 2		
10	<i>More Measurement</i>	Vernier Calipers	
11	<i>More Measurement</i>	Micrometers	
Practice Test	Practice Test How are you doing?	Get this page from your teacher	
Self-Assessment	Self-Assessment	On the next page, complete the self-assessment assignment.	
Unit Test	Unit Test Show me your stuff!		
Mental Math	Mental Math Non-calculator practice		

Self Assessment

In the following chart, show how confident you feel about each statement by drawing one of the following: ☺, ☹, or 😞. Then discuss this with your teacher **BEFORE** you write the test!

Statement	☺ ☹ 😞
After completing this unit;	
<ul style="list-style-type: none">I understand the relationship between units in the SI and imperial systems	
<ul style="list-style-type: none">I can convert a measurement from SI units to imperial units	
<ul style="list-style-type: none">I can convert a measurement from imperial units to SI units	
<ul style="list-style-type: none">I can estimate measurements using a referent in both SI and imperial systems	
<ul style="list-style-type: none">I can calculate perimeter, circumference, and area in metric and imperial units	
<ul style="list-style-type: none">I can calculate the surface area of a three-dimensional object in metric and imperial units	

Vocabulary: Chapter 3

base unit
foot (ft or ')
imperial system
inch (in or ")
mile (mi)
referent
surface area
Système international d'unités (SI)
yard (yd)

THE METRIC SYSTEM

The **Metric System** is a system of measurement based on multiples of 10, where the base unit for length is the metre. Since the 1960s, the International System of Units (SI) ("**Système International d'Unités**" in French, hence "SI") has been the internationally recognized standard metric system. Metric units are widely used around the world. To convert from one unit to another in the metric system, we multiply or divide by powers of 10 and attach a different prefix to the base unit (metre, for length). The standard set of prefixes used in the metric system and their meanings is found below.

PREFIX	SYMBOL	QUANTITY			
tera	T	trillion	1 000 000 000 000	1 000 000 000 000	10 ¹²
giga	G	billion	1 000 000 000	1 000 000 000	10 ⁹
mega	mg	million	1 000 000	1 000 000	10 ⁶
kilo	k	thousand	1000	1 000	10 ³
hecto	h	hundred	100	100	10 ²
deca	da	ten	10	10	10 ¹
basic unit		one	1	1	1
deci	d	one-tenth	0.1	1/10	10 ⁻¹
centi	c	one-hundredth	0.01	1/100	10 ⁻²
milli	m	one-thousandth	0.001	1/1000	10 ⁻³
micro	μ	one-millionth	0.000 001	1/ 1 000 000	10 ⁻⁶
nano	n	one-billionth	0.000 000 001	1/ 1 000 000 000	10 ⁻⁹
pico	p	one-trillionth	0.000 000 000 001	1/1 000 000 000 000	10 ⁻¹²

There are a lot of prefixes in the table above that we do not use on a daily basis, but no doubt you will have heard of many of these. My computer's hard drive is measured in GB – gigabytes, while newer ones are measured in TB - terabytes. And a common measurement in science is a nanometere – it is very small!

There are some prefixes that you need to know, and the relationship between them. These are the prefixes from kilometre to millimetre – km to mm. They are km, hm, dam, m, dm, cm, mm. There is a little rhyme that might help you remember the order of these units: **King Henry died, Mary didn't cry much**. Each first letter in this phrase, **khdm dcm**, represents the first letter in the corresponding unit, in order from km down to mm. The only area left for confusion is between decametres and decimeters. I remember these two because "a" comes before "i" in the alphabet and so decametres comes first in the little rhyme. **LEARN THIS RHYME!**

When you know the prefixes in order, it is easy to use them. Make a set of stairs and label the top step “km” and the bottom step “mm” and then fill in the rest using the rhyme like is shown here.

Notice that I have also put two arrows beside the staircase. These are used for converting between the units on the staircase.

If you are going **DOWN** the stairs, you will multiply by 10 for each step – now you put a “x” sign on the left of the “10” going down.

If you are going **UP** the stairs, you will divide by 10 for each step – now you put a “÷” sign to the left of the “10” going up.

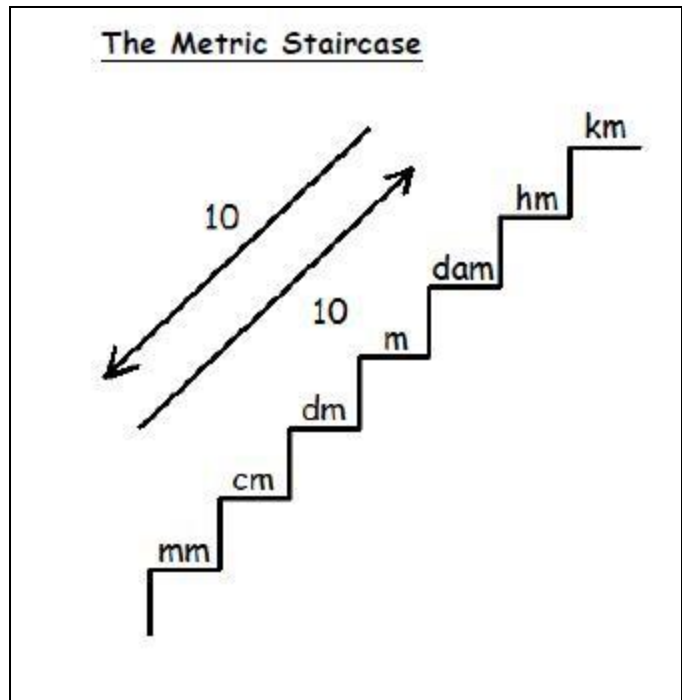

YOU NEED TO LEARN THIS STAIRCASE so you can use it as the order of the prefixes will NOT be given to you on the test or exam.

Another way to convert between the metric units is to either multiply or divide by 10 **for each** arrow as shown below.

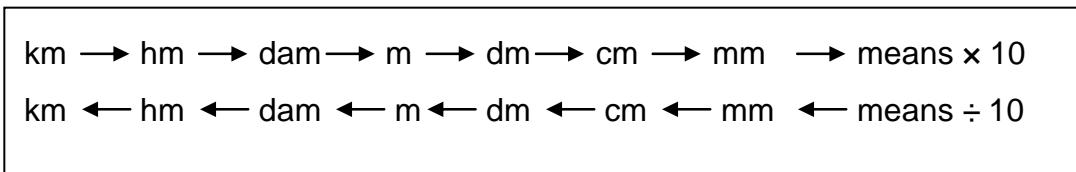

As with every system of measurement, different base units are used for different types of measurement. The following chart shows the different base units in the metric system.

MEASUREMENT	UNIT	SYMBOL
length	metre	m
mass	gram	g
capacity	litre	L
temperature	degrees Celsius	°C

These other measurements can also use “The Staircase” by simply replacing the m for metres with an L for litres or a g for grams. Just think of replacing Mary with Larry or Gary in the rhyme!!

Referents – objects that represent approximately one unit of measurement - for these units include: mm – the thickness of a paperclip, cm – the width of an adult baby finger, metre – the length of a pace (2 steps) or the height of a standard doorknob, for a metre.

Measuring with a metric ruler is usually done in centimeters or millimeters. Metric rulers are fairly easy to read. They show centimeters and millimeters. Answers and measurements are recorded in decimal numbers rather than fractions.

Look at the ruler below:

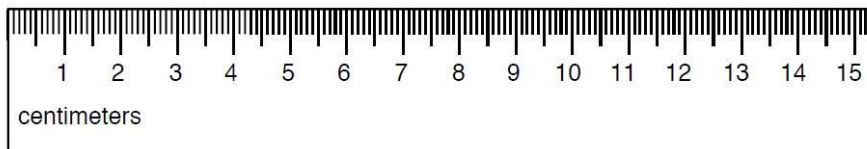

The larger lines with the numbers show the centimeters and the smaller lines in between them represent millimeters. Remembering that there are 10 mm in 1 cm, if you measure 8 lines after the 2 cm line – the arrow below - the measurement is 2.8 cm long.

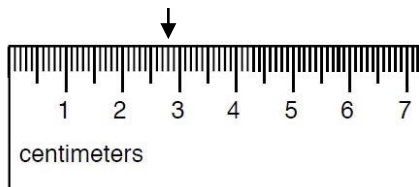

The measurement 2.8 cm can also be expressed as 28 mm.

ASSIGNMENT 1 – THE METRIC SYSTEM

Part A Choose the most sensible measure. Circle your answer.

- Length of a small paper clip.
31 mm 31 cm 31 m 31 km
- Length of a tennis racket.
68 mm 68 cm 68 m 68 km
- Distance around a racetrack.
2 mm 2 cm 2 m 2 km
- Length of a canoe
4 mm 4 cm 4 m 4 km
- Length of a key.
54 mm 54 cm 54 m 54 km
- Height of a woman.
160 mm 160 cm 160 m 160 km
- Width of a room.
8 mm 8 cm 8 m 8 km
- Distance from Vancouver to Hope.
125 mm 125 cm 125 m 125 km
- Length of a bowling alley.
18 mm 18 cm 18 m 18 km
- Height of a giant redwood tree.
67 mm 67 cm 67 m 67 km
- Length of a safety pin.
26 mm 26 cm 26 m 26 km
- Width of a desk.
75 mm 75 cm 75 m 75 km
- Long-distance run.
10 000 cm 10 000 m 10 000 km

Part B Convert the following measurements as indicated, using the Data Pages to help. SHOW YOUR WORK!

- 38 km $\times 1000 = \underline{38\,000}$ m
 - 0.4 km _____ = _____ cm
 - 758 mm _____ = _____ m
 - 0.52 km _____ = _____ mm
 - 8.5 m _____ = _____ mm
 - 2460 mm _____ = _____ cm
 - 155 cm _____ = _____ m
 - 1.6 m _____ = _____ km
 - 1245 m _____ = _____ km
 - 247 cm _____ = _____ mm
 - 16.5 m _____ = _____ cm
 - 2500 mm _____ = _____ km
- Note:** These units above are the common units used. Students are also responsible for knowing the less common units as illustrated in the following conversions.
- 30 dam _____ = _____ m
 - 67 dm _____ = _____ cm
 - 456 m _____ = _____ dam
 - 920 mm _____ = _____ dm
 - 7800 hm _____ = _____ km
 - 11 km _____ = _____ dm

Part C Solve the following questions. Show all your work.

1) The diameter of a loonie is about 26.5 mm. What is this measurement in centimetres?



2) A tree house is 1.2 m high. If each step is 20 cm high, will you need more or less than seven steps reach the tree house?

3) Nora needs 35 tiles for a floor. She finds a stack of tiles that is 0.5 m high. If each tile is 1.2 cm thick, are there enough tiles in the stack for her project?

4) William wants to put Christmas lights along the peak and edges of his roof. (bolded edges - see below)

a) How many metres of lights will he need?

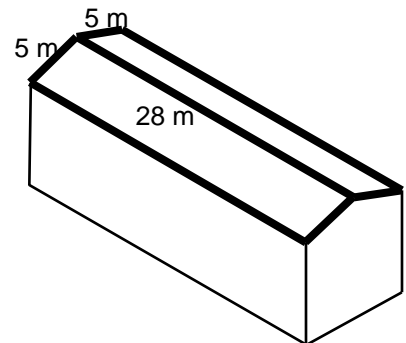

b) Express this length in cm.

Part D

State the length in cm and mm for all the objects measured on the rulers below.

1)

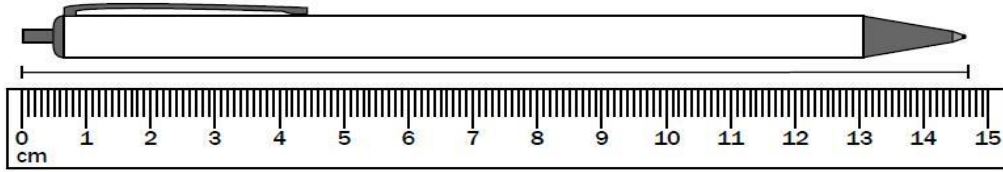

2)

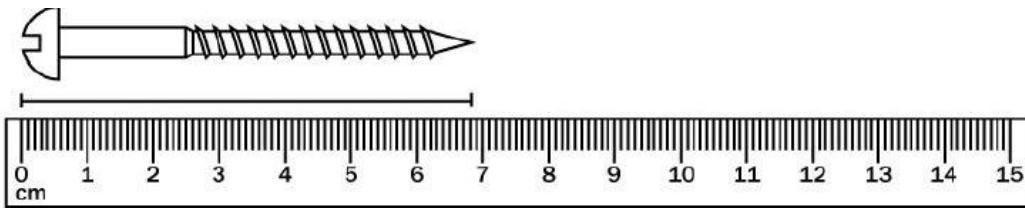

3)

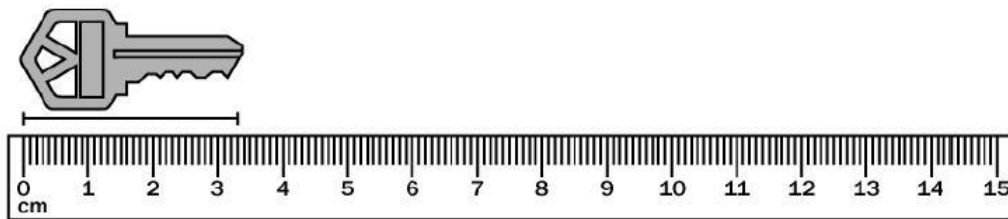

4)

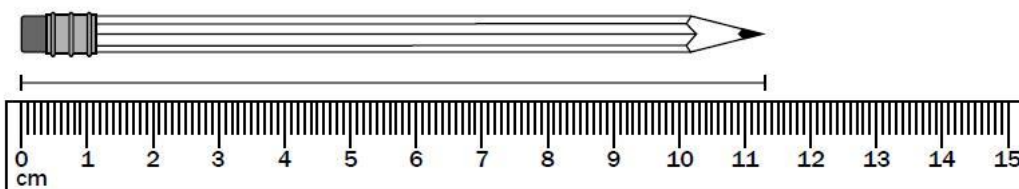

5)

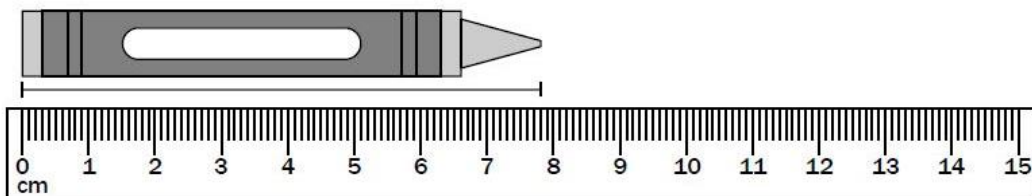

THE IMPERIAL SYSTEM

The Imperial System of measurement or **Imperial units** is a set of units, with the foot being the base unit. The units were introduced in the United Kingdom and the Commonwealth countries, but most countries now use the metric system. The exception is the United States. For measurements of length, the imperial system uses inches, feet, yards, and miles. It is important to be familiar with imperial measurements because they are still used in many areas like construction, and because the United States is so close to Canada.

Referents for these units include: inch – the width of an adult thumb, foot – the length of an adult foot, yard – the length from the nose to the end of the outstretched fingertip

The relationship between the units in the imperial system is not as friendly as the metric system. To convert between units requires knowledge of the divisions as shown below.

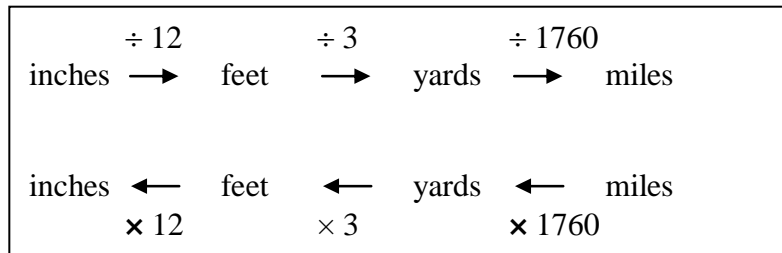

1 mile = 1760 yd
 1 mile = 5280 ft
 1 yd = 3 ft = 36 in
 1 ft = 12 in

The standard units used in the metric system (for length) are shown below.

UNIT	SYMBOL
inch	" or in.
foot	' or ft.
yard	yd.
mile	mi.

This imperial ruler shows inches which are divided into 16th. Often, rulers show the first inch divided into 32nd of an inch. Each inch on the ruler is marked with a long line and is labeled 1, 2, 3, 4, and so on. In between each inch marker is another long line which marks each half inch. In between each of these divisions is a slightly longer line which marks each quarter ($\frac{1}{4}$) of an inch.

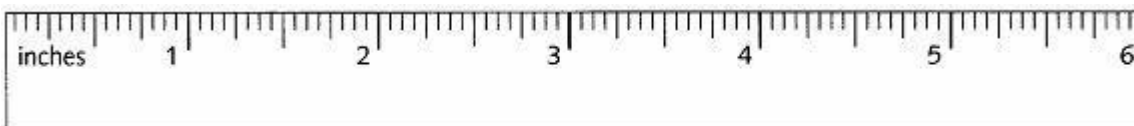

ASSIGNMENT 2 – IMPERIAL SYSTEM

Part A

To measure a length using an imperial ruler, count the whole number of inches, and then count the number of 16th of the next inch until the mark is reached. For example, letter H below is pointing at a measurement of $5 \frac{5}{16}$ in.

1. State the length (to the closest $\frac{1}{16}$ th of an inch) for all the points on the ruler below.

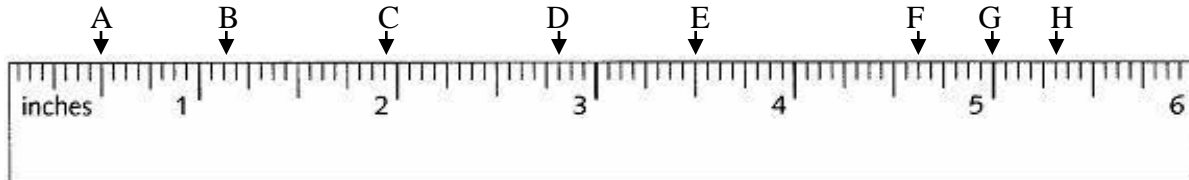

2. Find the length of the lines below to the closest $\frac{1}{16}$ th of an inch.

a)

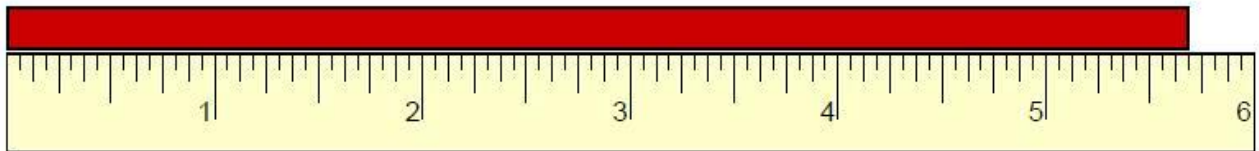

b)

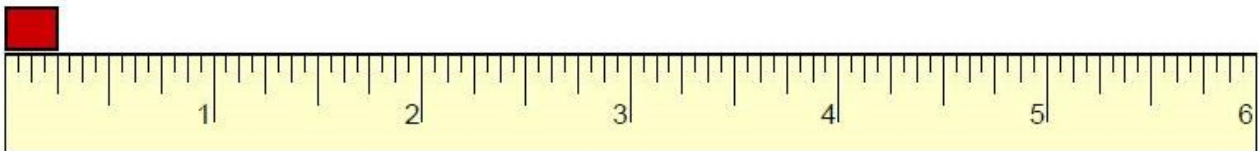

c)

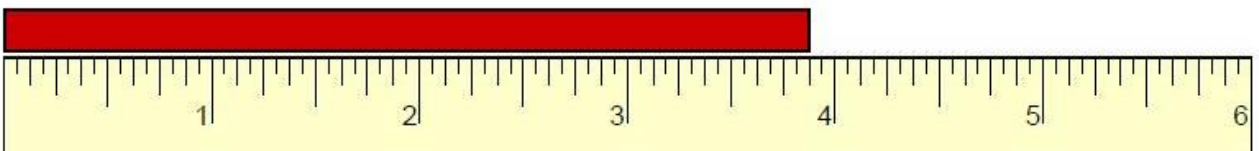

d)

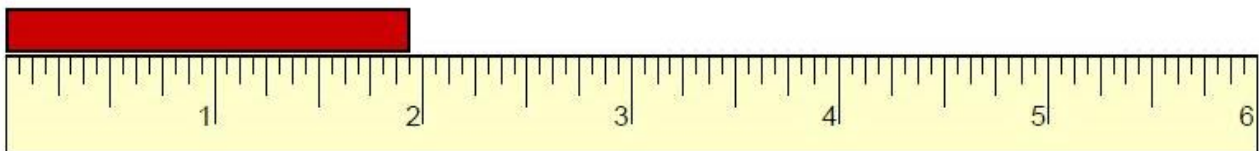

3) Convert the following measurements. SHOW YOUR WORK!

a) 38 ft _____ = _____ in

b) 0.4 mi _____ = _____ yd

c) 7.5 mi _____ = _____ ft

d) 72 in _____ = _____ ft

4) Ray is building a fence around his yard using pre-made panels that are sold in 8 ft lengths. The perimeter of the yard is 32 yd. How many fence panels should he buy?

Often Imperial Units are used in combination. These need to be converted to only one unit.

Example, Jan might say she is 5 ft 10 in tall.

How tall is Jan in inches?

1 ft = 12 in.

So, 5 ft × 12 in. = 60 in.

How tall is Jan in feet?

1 ft = 12 in.

So, 10 in. ÷ 12 in = 0.83 ft

Jan's height in inches is:

60 in. + 10 in. = 70 in.

Jan's height in feet is:

5 ft + 0.83 ft = 5.83 ft

Part B

5) Convert the following measurements.

a) 7 yd 2 ft _____ = _____ ft

b) 3 yd 1 ft _____ = _____ in

c) 9 yd 11 ft _____ = _____ ft

d) 7 mi 2 yd _____ = _____ ft

e) 5 mi 16 yd 2 ft _____ = _____ in

- 6) The Olympic Marathon is a running race that is 26 miles 385 yards long. If Sebastian's stride is about 1 yard long, how many strides will he take in a marathon run?
- 7) If each board in a fence is 6 inches wide, how many boards will Josée need to fence all 4 sides of a playground that is 60 ft wide by 125 feet long?
- 8) Riley bought 50 ft of rope. He cut off pieces that total 34' 8" so far. How much rope does he have left?
- 9) A circular garden has outside circumference (perimeter of a circle) of 23 feet. If a geranium is planted every 6 inches around the garden, how many geraniums are needed?
- 10) A pet store has 10 cages for sale. They are 5 cages that are 2'8" wide, 3 cages that are 4'6" wide, and 2 cages that are 1'8" wide. Can these cages fit side by side along a wall that is 30' long?

Imperial Units are also stated in fraction form, but can be converted to decimal form. Using decimal form is easier when converting measurements.

Example: A staircase is $4 \frac{3}{4}$ feet long. What is this height in inches?

Solution: Change the fraction to a decimal, and then convert the feet to inches.

To change a fraction to a decimal, divide the numerator (top number) by the denominator (bottom number).

So $\frac{3}{4}$ becomes $3 \div 4 = 0.75$

And $4 \frac{3}{4}$ can be changed to a decimal as follows:

$$4 \frac{3}{4} = 4 + 3 \div 4 = 4.75 \text{ feet}$$

Now change the feet to inches. Remember, 1 foot = 12 inches.

$$4 \frac{3}{4} \text{ feet} = 4.75 \times 12 = 57 \text{ inches}$$

Part C

11) Convert the following measurements.

a) $6 \frac{1}{4}$ yd _____ = _____ ft

b) $\frac{1}{4}$ ft _____ = _____ in

c) $2 \frac{3}{4}$ mi _____ = _____ ft

d) $4 \frac{1}{2}$ mi _____ = _____ yd

CONVERTING MEASUREMENTS BETWEEN SYSTEMS

It is important to be able to convert metric units to imperial units, and vice versa. Below are the common conversions used in the Data Pages for units of length. Note that the sign “ \approx ” means approximately. These conversions are not exact but are what will be used for this course. Online conversions calculators give more precise conversions if needed.

1 inch \approx 2.54 centimetres
1 foot \approx 30.48 centimetres
1 foot \approx 0.3048 metres
1 yard \approx 0.9144 metres
1 mile \approx 1.609 kilometres

These conversion factors came from your **DATA PAGES**. Use them to help you make conversions!.

Example 1: Convert 24 ft _____ = _____ m

Solution: The conversion from ft to m is 0.3048. This is a left to right conversion so multiply.

$$\text{So, } 24 \text{ ft} \times 0.3048 = 7.3152 \text{ m} = 7.32 \text{ m}$$

Example 2: Andrea's height is 5'8". What is her height in centimetres?

Solution: First convert Andrea's height all to inches.

$$5' \times 12 = 60" + 8" = 68"$$

Then change the inches to centimetres by using the conversion factor. This can be done by multiplying or by setting up a proportion and solving.

$$68" \times 2.54 = 173 \text{ cm}$$

$$\frac{\text{cm}}{\text{in.}} \quad \frac{2.54}{1} = \frac{x}{68}$$

$$x = 2.54 \times 68 \div 1 = 173 \text{ cm}$$

Example 3: Convert 675 in. _____ = _____ m

Solution: Convert inches to feet, and feet to metres.

$$675 \text{ in.} \div 12 = 56.25 \text{ feet}$$

$$56.25 \text{ ft} \times 0.3048 = 17.145 \text{ m} = 17.15 \text{ m}$$

ASSIGNMENT 3 – CONVERTING MEASUREMENTS BETWEEN SYSTEMS

1) Convert the following measurements. SHOW YOUR WORK! Round your answers to **two decimal places**. The first one is done for you.

a) 8 in $\times 2.54 = 20.32 \text{ cm}$

f) 27 cm _____ = _____ in

b) 9.5 mi _____ = _____ km

g) 1.5 m _____ = _____ ft

c) 25 yd _____ = _____ m

h) 123 km _____ = _____ mi

d) 67 ft _____ = _____ m

i) 145 in _____ = _____ cm

e) 24 ft _____ = _____ cm

j) 55 cm _____ = _____ ft

- 2) Mount Logan is Canada's highest mountain. It measures 19 551 ft. What is that height in metres? Round your answer to one decimal place.
- 3) The Capilano Suspension Bridge in North Vancouver is 173 m across and 70 m above the river. What are these distances in feet? Round your answers to one decimal place.
- 4) Jiri's boat and trailer is 20 ft 6 in. long. His garage is 6.2 m long. Will the boat and trailer fit in his garage? Round your answer to 4 decimal places. (Change ft & in to metres)
- 5) Charlie drove from Calgary to Saskatoon. If this distance is 620 km, how far is this in miles? Round your answer to one decimal place.
- 6) Carla needs 3.5 m of cloth. However, the cloth she wants to buy costs \$9.79 per yard. How much will this cloth cost? Round the yards to 2 decimal places.
- 7) A nickel is 1.95 mm thick. About how long is a \$2.00 roll of nickels in inches? Round your answer to the nearest whole inch. Hint: How many nickels (5¢) are in \$2.00?
- 8) An airline has size limits for checked baggage. The length, width and height of all luggage must add up to no more than 157 cm. Will the airline accept a suitcase that measures 17 in. by 26 in. by 14 in.?

ASSIGNMENT 4 – METRIC AND IMPERIAL ESTIMATION

Different units are appropriate to be used when estimating or stating the size of something. For example, you wouldn't say that the desk you are sitting at is so many kilometres long, or the distance you live from school is that many millimetres. These are not appropriate units.

1. Complete the following chart. Write the appropriate **units** for each measurement.
Choose from the following: metric – mm, cm, m, km
imperial – in., ft., mi. (yds are used in sports)

Item	Metric	Imperial
Length of a Translink bus		
Length of a \$20 bill		
Height of a 1-story building		
Width of your pencil		
Size of your big screen TV		

2. Estimate the following lengths in both metric and imperial. Give both a number and the appropriate units.

Item	Metric	Imperial
Length of a your desk		
Length of a pencil		
Height of a flagpole		
Width of an eraser		
Distance from Surrey to Vancouver		

ASK YOUR TEACHER FOR QUIZ 1

PERIMETER

The distance around any geometric shape is known as the perimeter. To calculate the perimeter, simply add the lengths of all the sides together. Perimeter is always in linear units: cm, in, ft, m, etc.

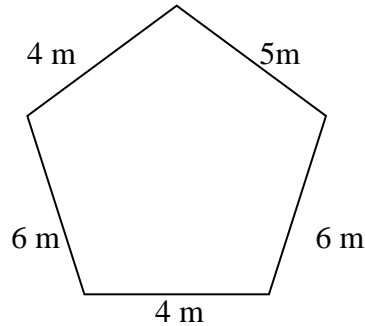

The perimeter of this figure is:
 $P = 4 + 5 + 6 + 4 + 6 = 25 \text{ m}$

A rectangle has a special formula that can be used to calculate its perimeter. The perimeter is two of the length plus two of the width. It doesn't matter which side is called the length and which one is called the width. In math terms, this means times the length plus two times the width.

$$P = 2 \times l + 2 \times w$$

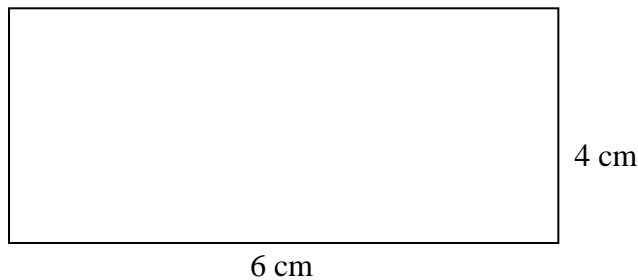

$$P = 2 \times l + 2 \times w$$

$$P = 2 \times 6 + 2 \times 4$$

$$P = 12 + 8$$

$$P = 20 \text{ cm}$$

The perimeter of EVERY figure is always calculated in the units given in the question. If the units in the figure are cm, the perimeter is cm; if it is in inches, the perimeter is in inches, and so on.

When solving word problems, ALWAYS draw a diagram to help you!

ASSIGNMENT 5 – PERIMETER

Calculate the perimeter of the following figures. Show your work and include the proper units in your answer.

1a)

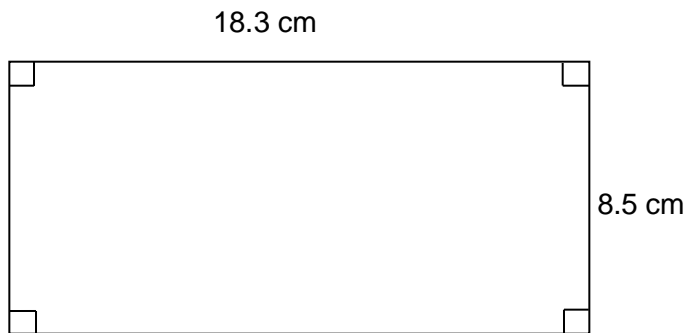

b)

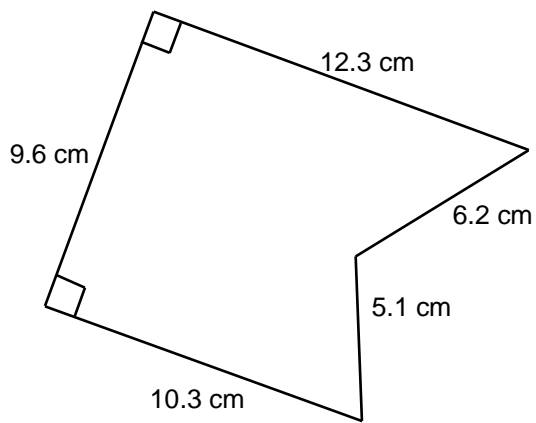

c)

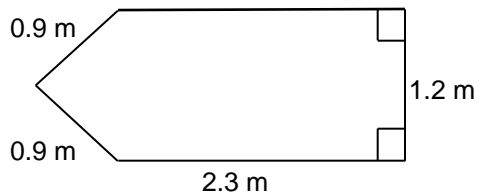

- 2) Darlene is adding lace to the edge of a tablecloth. The tablecloth is 210 cm by 180 cm. How many centimetres does she need to go all the way around the tablecloth?



- 3) Chandra is building a fence around her swimming pool to completely surround it. The pool is 25 feet long and 12 feet wide. There is a 6 ft walkway around the entire pool. How much fencing will she need?

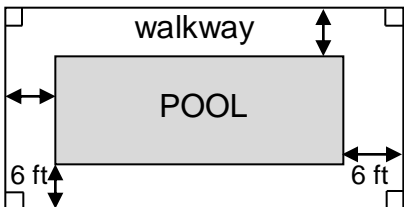

- 4) A rectangular city pool is 40 ft wide and has a perimeter of 230 ft. What is the length of the pool?

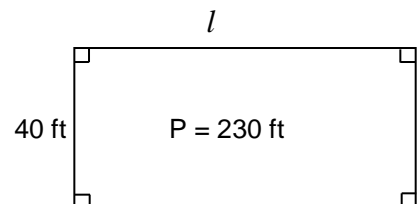

CIRCUMFERENCE

The perimeter of a circle has a special name and formula as it is impossible to “measure” a circle’s sides! The special name for perimeter of a circle is the circumference.



The formula for circumference of a circle is:

$$C = 2\pi r \quad \text{OR} \quad C = \pi d \quad \text{where}$$

r = radius of a circle

d = diameter of a circle

π = pi, a constant found on your calculator.

It has a value of approximately 3.14159

The diameter is twice the size of the radius, or the radius is half the size of the diameter. In this circle, the diameter $d = 14$ m so the radius = 7 m.

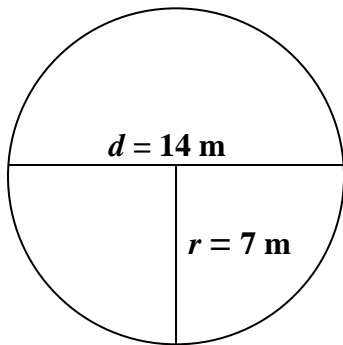

Thus the circumference calculation is:

$$C = 2\pi r$$

OR

$$C = \pi d$$

$$C = 2 \times \pi \times 7$$

$$C = \pi \times 14$$

$$C = 43.98 \text{ m}$$

$$C = 43.98 \text{ m}$$

Use the π button on your calculator. If you have difficulty finding it, please ask your teacher.

Just like straight edged shapes, the perimeter of circles is always calculated in the units given in the question. If the units in the figure are cm, the perimeter is cm; if it is in inches, the perimeter is in inches.

ASSIGNMENT 6 – CIRCUMFERENCE

Use the π button on your calculator. Include the proper units in your answer. Round each answer to one decimal place. SHOW YOUR WORK!

- 1) Simon works for Surrey Water Department. He is ordering the liner for a new overflow tunnel at the pumping station. The tunnel is shown to the right.

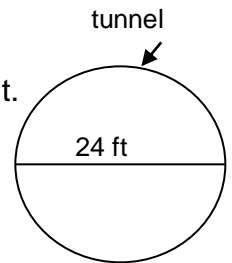

- a) What is the radius of the tunnel?

$$\begin{aligned}\text{Radius} &= \text{diameter} \div 2 \\ &= \underline{\hspace{2cm}} \text{ ft} \div 2 \\ &= \underline{\hspace{2cm}} \text{ ft}\end{aligned}$$

- b) What is the circumference of the tunnel? Show these 2 ways to calculate it.

$\begin{aligned}\text{Circumference} &= 2 \times \pi \times \text{radius} \\ &= 2 \times \pi \times \underline{\hspace{2cm}} \text{ ft} \\ &= \underline{\hspace{2cm}} \text{ ft}\end{aligned}$	$\begin{aligned}\text{Circumference} &= \pi \times \text{diameter} \\ &= \pi \times \underline{\hspace{2cm}} \text{ ft} \\ &= \underline{\hspace{2cm}} \text{ ft}\end{aligned}$
---	---

The circumference of the tunnel liner should be ft.

- 2) Calculate the circumference of the following circles. (2 decimal places)

a)

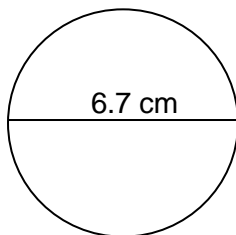

b)

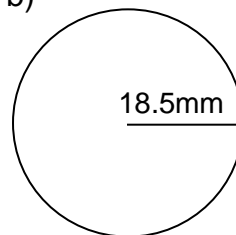

- 3) A circular fountain has a radius of 10.6 m. What is its circumference? (one decimal place)

4) Michelle is a cake decorator. Her icing bag holds enough icing to make a line 4.6 m long. She wants to draw circles around the top edges on some cakes like seen here.



a) What is the circumference of this cake? (one decimal place)

b) How many whole cakes like this one can Michelle draw these circles on with one full icing bag?

5) The sides of a flower garden are shown in the diagram below. What is the perimeter of the flower garden? (one decimal place)

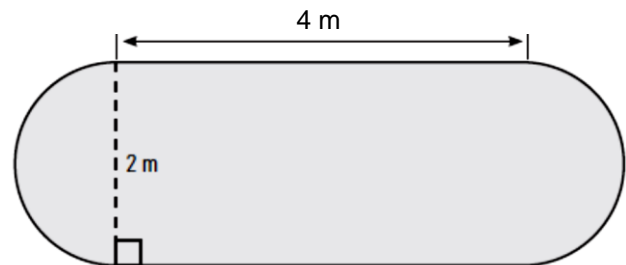

6) Mike sells tires. A customer told him the circumference of the wheel rim on his tires, but Mike needs the diameter to get the correct tire size. If the circumference of the customer's rim is 66 in., what is the diameter? (closest whole number)



AREA

In geometry, **area** refers to *the measure of a region*. It is ALWAYS in square units – cm², in², m², etc. The area of a geometric figure is the number of square units needed to cover the interior of that figure. The following formulas are used to find area. These formulas are provided for you on a sheet similar to the one at the end of this booklet for the provincial exam.

In equations, the symbol for area is a capital a → **A**.

Rectangle:

Area is the length (or base) times the width (or height). Both terms are used depending on author.

$$A = l \times w \quad \text{or} \quad A = b \times h$$

Example:

$$\begin{aligned} A &= l \times w \\ &= 15 \times 6 \\ &= 90 \text{ m}^2 \end{aligned}$$

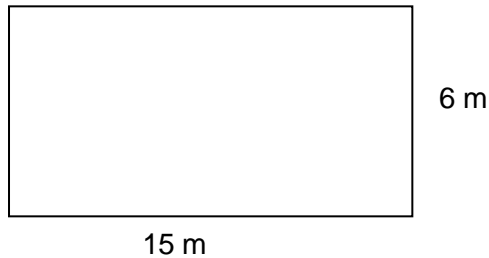

Square:

In a square, all the sides have the same length. So the area is the side times side, or side squared.

$$A = s \times s \quad \text{or} \quad A = s^2$$

Example:

$$\begin{aligned} A &= s^2 \\ &= 7 \times 7 \\ &= 49 \text{ cm}^2 \end{aligned}$$

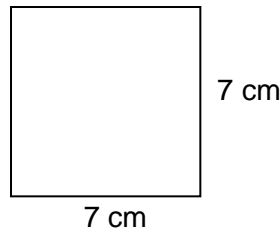

Triangle:

A triangle is any 3 sided figure. It can have any other combination of angles. The area is base times the height divided by 2. The height is always perpendicular (at right angles or 90°) to the base.

$$A = \frac{1}{2}(b \times h) \quad \text{which means} \quad A = b \times h \div 2$$

Example:

$$\begin{aligned} A &= b \times h \div 2 \\ &= 6 \times 9 \div 2 \\ &= 27 \text{ cm}^2 \end{aligned}$$

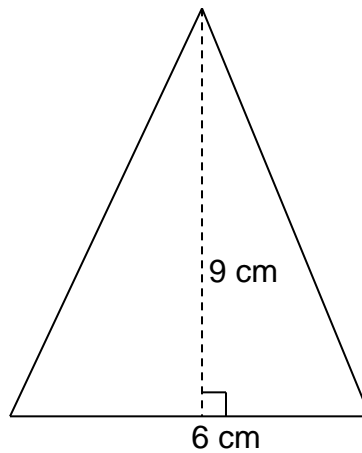

These are other shapes of triangles that still follow this formula.

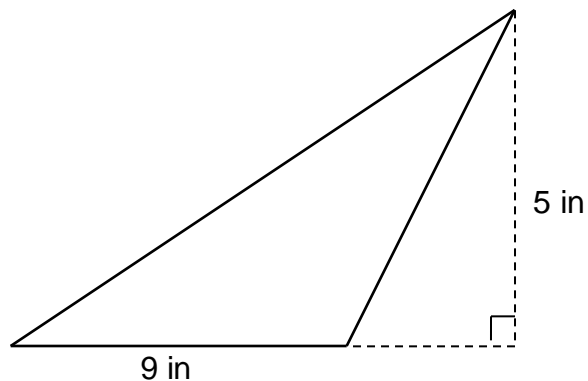
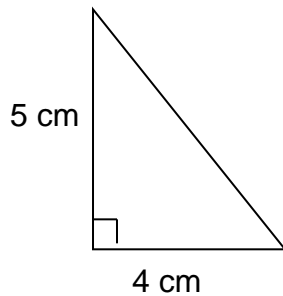

Circle:

In a circle, there are no “sides”. So the area is calculated using the length of the radius in the following formula. Remember, the radius goes from the centre of the circle to touch the circle at any place. Use the π button on your calculator.

$$\mathbf{A = \pi r^2 \quad \text{which means } A = \pi \times r \times r}$$

Example:

$$\begin{aligned} \mathbf{A} &= \mathbf{\pi r^2} \\ &= \mathbf{\pi \times 6 \times 6} \\ &= \mathbf{113.10 \text{ cm}^2} \end{aligned}$$

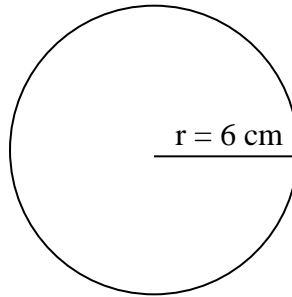

Remember, if given the diameter, divide that number by 2 before calculating the area because the radius is half the length of the diameter.

$$\begin{aligned} \mathbf{r} &= \mathbf{d \div 2} \\ &= \mathbf{18 \div 2} \\ &= \mathbf{9 \text{ in}} \end{aligned}$$

$$\begin{aligned} \mathbf{A} &= \mathbf{\pi r^2} \\ &= \mathbf{\pi \times 9 \times 9} \\ &= \mathbf{254.47 \text{ in}^2} \end{aligned}$$

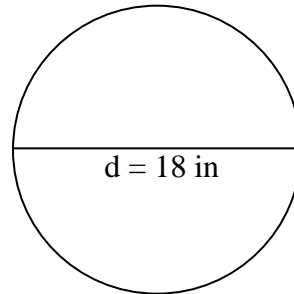

ASSIGNMENT 7 – AREA

For each of the following, name the shape and calculate its area. Write the formula at the start of your calculations as part of your answer. DON'T FORGET THE UNITS!

1)

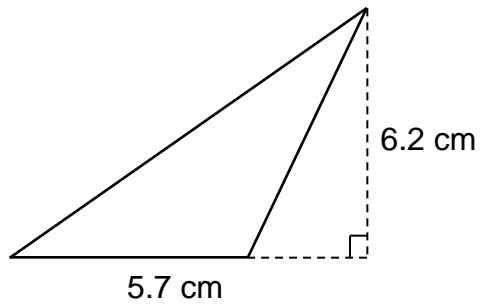

2)

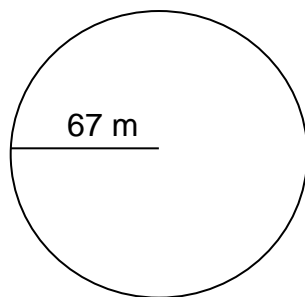

3)

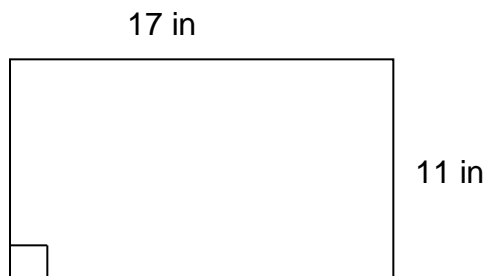

MORE AREA

When completing area calculations between units, **it is best to change the linear dimensions to the new unit before calculating the area.**

Example:

Kuldeep must tile a floor that measures 4.4 m by 3.8 m.

a) What is the area he must cover in square inches?

First, change the dimensions of the floor into inches.

$$4.4 \text{ m} \div 0.3048 = 14.43 \text{ ft} \times 12 = 173.16 \text{ in}$$

$$3.8 \text{ m} \div 0.3048 = 12.46 \text{ ft} \times 12 = 149.51 \text{ in}$$

$$\text{Area}_{(\text{floor})} = 173.16 \times 149.51 = 25\,889.15 \text{ in}^2 \rightarrow 25\,889 \text{ in}^2$$

b) The tiles are 9" by 9". How many full tiles will he need?

First, find the area of the tiles.

$$\text{Area}_{(\text{tile})} = 9" \times 9" = 81 \text{ in}^2$$

Next, divide the area of the floor by the area of the tile.

$$25\,889 \text{ in}^2 \div 81 \text{ in}^2 = 319.62 \text{ tiles} \rightarrow 320 \text{ tiles}$$

Sometimes, area must be changed from one square unit to another. This must be done carefully!

Consider the square to the right. It has side lengths of 10 mm or 1 cm.

When finding the area of this face, we could use either measurement.

$$\begin{aligned} \text{Area} &= s \times s \\ &= 10 \text{ mm} \times 10 \text{ mm} \\ &= 100 \text{ mm}^2 \end{aligned}$$

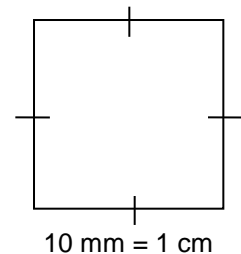

But the following is also true

$$\begin{aligned} \text{Area} &= 1 \text{ cm} \times 1 \text{ cm} \\ &= 1 \text{ cm}^2 \end{aligned}$$

Therefore, **1 cm² = 100 mm²**

When converting between cm² and mm², this must be observed. The following are also true based on this example.

$$1 \text{ m}^2 = 10\,000 \text{ cm}^2$$

$$1 \text{ yd}^2 = 9 \text{ ft}^2$$

$$1 \text{ km}^2 = 1\,000\,000 \text{ m}^2$$

$$1 \text{ ft}^2 = 144 \text{ in}^2$$

These are important conversions to know especially for the Provincial Exam!

ASSIGNMENT 8 – MORE AREA

1) Leonard is laying grass in a yard measuring 38 ft by 20 ft. What is the yard's area in square yards? Change the feet to yards first! (Round answers to two decimal places)

2) Suzanne needs to buy grass seed for the park. The park is 150 m by 210 m. Grass seed is sold by the square foot. How many square feet are in the park? Change the metres to feet first! (Round all answers to closest whole number)

3) A room measures 12'8" by 10'9". Carpeting costs \$45.98/m².

a) Change these measurements to metres. Round all answers to 2 decimals.

b) What is the area of this room in square metres? Round answer to 2 decimals.

b) What is the cost of the carpeting for this room?

SURFACE AREA

The surface area of a three-dimensional object is the area of the entire outer surface.

There are specific formulas used to find the surface area of different geometric solids.

These formulas are in your Data Booklet as well as being explained here. Just as area is expressed in square units, surface area is also **ALWAYS** expressed in square units; – cm^2 , in^2 , m^2 , etc.

Rectangular Solid:

Surface area is calculated by finding the area of each of the three faces by multiplying length times width for the face, and then adding these areas of all 6 surfaces together.

$$\mathbf{SA = 2lw + 2lh + 2wh} \quad \text{or} \quad \mathbf{SA = 2 \times l \times w + 2 \times l \times h + 2 \times w \times h}$$

This represents the top & bottom, the front & back, and both ends.

Alternate formulae: $SA = 2(lw + lh + wh)$ and $SA = lw + lw + lh + lh + wh + wh$

Example:

$$\begin{aligned} \mathbf{SA} &= \mathbf{2lw + 2lh + 2wh} \\ &= 2 \times 15 \times 6 + 2 \times 15 \times 12 + 2 \times 6 \times 12 \\ &= 180 + 360 + 144 \\ &= 684 \text{ m}^2 \end{aligned}$$

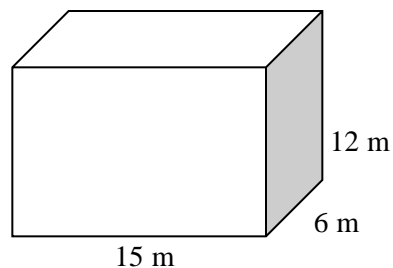

Cube:

A cube is a special rectangular solid that has sides that all have the same length. So the surface area is side times side multiplied by 6 sides.

$$\mathbf{SA = s \times s \times 6} \quad \text{or} \quad \mathbf{SA = 6s^2}$$

Example:

$$\begin{aligned} \mathbf{SA} &= \mathbf{6s^3} \\ &= 6 \times 7 \times 7 \\ &= 294 \text{ cm}^2 \end{aligned}$$

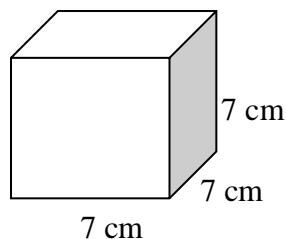

Cylinder:

The surface area of a cylinder is a two part formula. The first part multiplies 2 times π times the radius times the height for the side of the cylinder. This represents the area of side of the cylinder (it's a rectangle). Then the top and bottom circles must be added. The area of each of these is π times the radius, times the radius or radius squared (r^2). As there are 2 circles, this must be multiplied twice.

$$\mathbf{SA = 2\pi rh + 2\pi r^2}$$

which means $\mathbf{SA = 2 \times \pi \times r \times h + 2 \times \pi \times r \times r}$
side top & bottom

Example:

$$\begin{aligned}\mathbf{SA} &= \mathbf{2\pi rh + 2\pi r^2} \\ &= \mathbf{2 \times \pi \times 3 \times 9 + 2 \times \pi \times 3 \times 3} \\ &= \mathbf{169.65 + 56.55} \\ &= \mathbf{226.2 \text{ in}^2}\end{aligned}$$

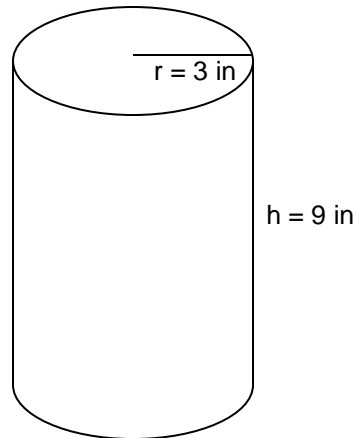

Cylinders can be tall like this can (can of pop), or short and fat like the diagram below (can of tuna). Either way the radius is measured on the round part and the height between each circle.

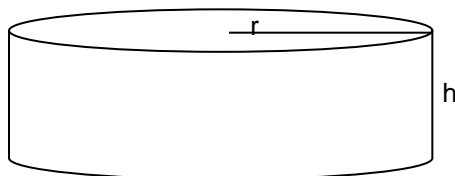

Remember, if you are given the diameter of the cylinder, divide it by 2 to get the radius.

$$\begin{aligned}r &= d \div 2 \\ r &= 14 \text{ cm} \div 2 \\ r &= 7 \text{ cm}\end{aligned}$$

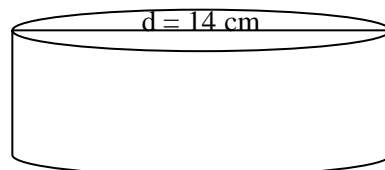

Cone:

The surface area of a cone is a two part formula found by multiplying π times the radius times the slant height plus π times radius times radius.

$$\mathbf{SA = \pi rs + \pi r^2} \quad \text{which means } \mathbf{A = \pi \times r \times s + \pi \times r \times r}$$

side base

Example:

$$\begin{aligned} \mathbf{SA} &= \mathbf{\pi rs + \pi r^2} \\ &= \mathbf{\pi \times 6 \times 9 + \pi \times 6 \times 6} \\ &= 169.65 + 113.10 \\ &= 282.75 \text{ cm}^2 \end{aligned}$$

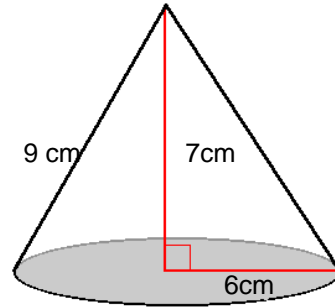

NOTE: If the base is not included, omit the circle part of the formula for the base: (πr^2)

Sphere:

The surface area of a sphere is found by multiplying four times π times the radius times the radius.

$$\mathbf{SA = 4\pi r^2} \quad \text{which means } \mathbf{SA = 4 \times \pi \times r \times r}$$

Example:

$$\begin{aligned} \mathbf{SA} &= \mathbf{4\pi r^2} \\ &= \mathbf{4 \times \pi \times 5 \times 5} \\ &= \mathbf{314.16 \text{ m}^2} \end{aligned}$$

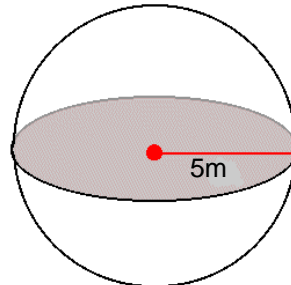

Pyramid:

The surface area of a pyramid is found by multiplying 2 times the base edge of the pyramid (**b**) times the slant height (**s**) plus the base edge of the pyramid (**b**) times the base edge of the pyramid (**b**).

$$SA = 2bs + b^2 \text{ which means } SA = 2 \times b \times s + b \times b$$

Example:

$$\begin{aligned} SA &= 2bs + b^2 \\ &= 2 \times 12 \times 9 + 12 \times 12 \\ &= 216 + 144 \\ &= 260 \text{ m}^2 \end{aligned}$$

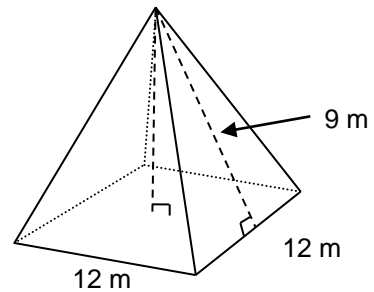

Be careful to use the slant height of the pyramid in this formula, not the height. The height goes from the vertex at the top to the middle of the base while the slant height of a face goes from the vertex at the top to the middle of the bottom of one of the sides.

ASSIGNMENT 9 – SURFACE AREA

Part A

Calculate the surface area of the figures shown below. Show all your work. Round answers to one decimal place as needed.

1)

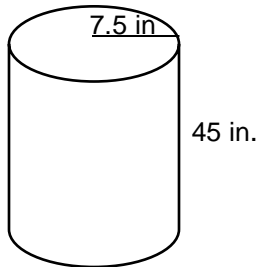

2)

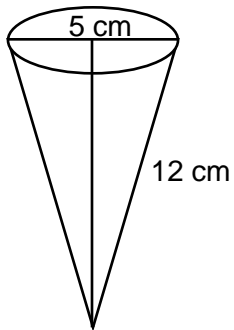

3)

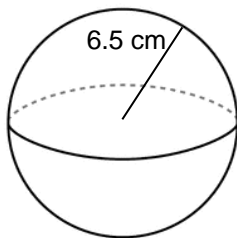

4)

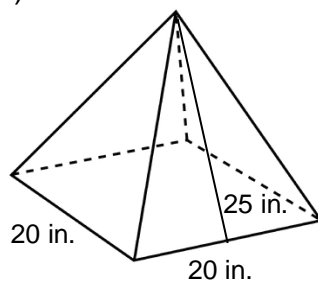

Part B

1) Jim is making a toy box. The box is 24 in. long, 18 in. deep and 36 in. tall.

a) Label the toy box drawn below.

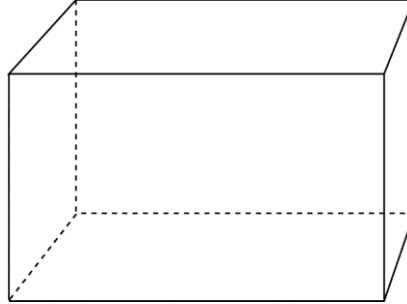

b) Calculate the surface area of the toy box in square inches.

2) Vicki is tiling her shower stall. The dimensions of the shower stall are 35" by 35" by 8 feet tall. If Vicki only needs to tile 3 sides (the 4th side is the door!), what is the surface area she will be tiling? Hint: the 3 sides are all the same size. Calculate the area of one of these surfaces, and then multiply it by 3.

3) Sanjay designs a cylindrical container to hold tennis balls. Four tennis balls will fit inside, stacked on top of each other. The tennis balls have a diameter of $3\frac{1}{4}$ inches each.

a) Label the sketch below to represent this container.

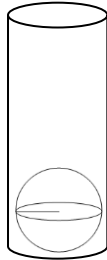

b) Calculate the surface area of the whole container, to one decimal place.

4) A paper cup in the shape of a cone has a slant height of $3\frac{1}{8}$ inches and a diameter of 3 inches. How much paper is needed to make the cup? (Remember it's just the sides!) Round to one decimal place.

5) Denise has an octagonal (8-sided) fish tank. The tank is 4 feet tall and each piece of glass is $1\frac{1}{2}$ feet wide. How much glass is in the fish tank?

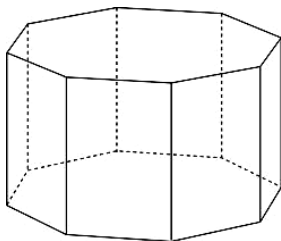

ASK YOUR TEACHER FOR QUIZ 2

More Measurement

Rulers, metre sticks, and measuring tapes can give measurements to the nearest millimetre, or to the nearest 0.1 cm. Other measuring instruments can more accurately be measure to the nearest tenth of a millimetre, or 0.01 cm, or even to the nearest one thousandth of a millimetre or 0.001 mm depending on their scales.

The two measuring instruments you will be learning about in the booklet are the caliper and the micrometer.

Vernier Calipers

A Vernier caliper is an instrument for making accurate linear measurements. It was invented by a French engineer named Pierre Vernier in 1613. It is a common tool in that laboratories and other industries that require precise measurements. Manufacturing of aircraft, buses, and scientific instruments are a few examples of industries in which precision measurements are essential.

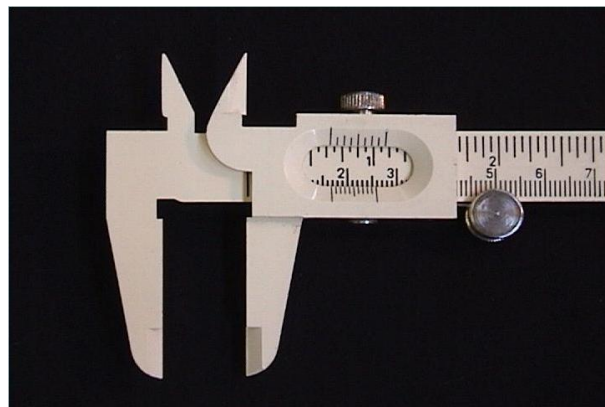

used

used

Vernier caliper

A vernier caliper (or it is often just called a “vernier” or “caliper”) is a convenient tool to use when measuring the length of a small object, or the outer or inner diameter of a round object like a pipe or hole. A vernier caliper can measure accurately to 0.01 cm, or 0.1 mm.

Reading a vernier calliper is not difficult. Once the jaws of the vernier are in place, the scales are set and the reading can be made.

There are two scales used for measuring with callipers: SI (metric) and imperial scales. These two scales can sometimes be found on the same calliper, one on the top and one on the bottom. When using each scale, the procedure for determining each measurement is slightly different. Only SI calipers will be discussed here.

Reading SI or Metric Callipers

When measuring with a metric caliper, the final measurement will usually be in centimetres (cm). There are 3 steps needed to read these vernier calipers. Each step is done independently and then the values are all added together.

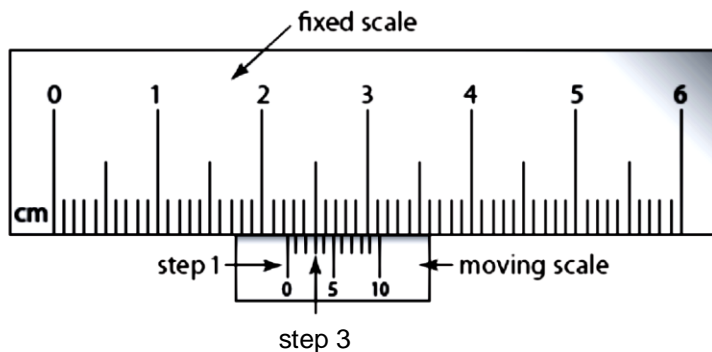

In this example, the moveable scale is on the bottom of the fixed scale. (It can also be on the top.) The numbers at the top of the fixed scale are in centimetres. Notice that there are tick marks on the fixed scale between the numbers. These are in millimetres or tenths of a centimetre. Therefore, there are 10 ticks between the numbers. There are also 10 tick marks on the moveable scale.

Step 1: Locate the “0” on the moveable or sliding scale. Now you need to determine where the “0” is. In this example, the zero is between 2 and 3 cm so we know our reading will be at least 2 cm. This is our first part of the reading and can be recorded as follows:
2. ____ ____ cm. Our goal is to fill in the two blanks to finish the reading.

Step 2: Now you must determine the next blank which represents the tenths of a centimetre. To do this, look carefully at the tick marks between 2 and 3 centimetres on the fixed scale. You can see that the zero line has gone past the second tick but has not yet reached the third tick. So we write down a “2” for the next blank. So our reading now looks like this:

2.2 ____ cm

Step 3: You will use the ticks on the moveable scale for the final reading. Look for where one of the ticks on the movable scale lines up or matches best with a tick mark directly above it on the fixed scale. In this example, the arrow shows that the third tick matches up most closely with the line on the fixed scale. So the value for the third blank must be a 3, and our reading would be:

2.23 cm

Note: for this final reading, it doesn't matter which line is matched on the fixed scale as we read from the moveable scale.

This may sound complicated but it really is not once you try a few. Now you are ***required*** to watch a video with your teacher. It will show you exactly what was just explained and last about a minute and a half.

This site has a simulation that allows you to move the sliding scale and then practice reading the caliper.

<http://www.physics.smu.edu/~scalise/apparatus/caliper/tutorial/>

<http://www.members.shaw.ca/ron.blond/Vern.APPLET/>

ASSIGNMENT 10 – VERNIER CALIPERS

Now try these calipers and write their measurements down underneath each caliper.

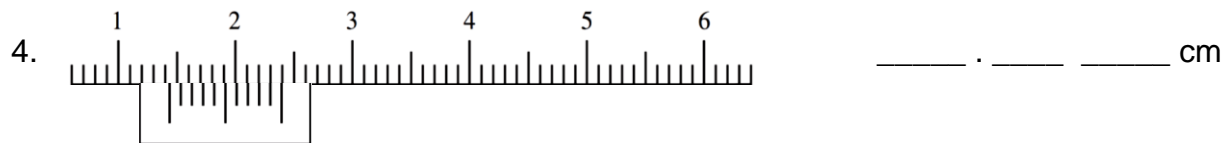
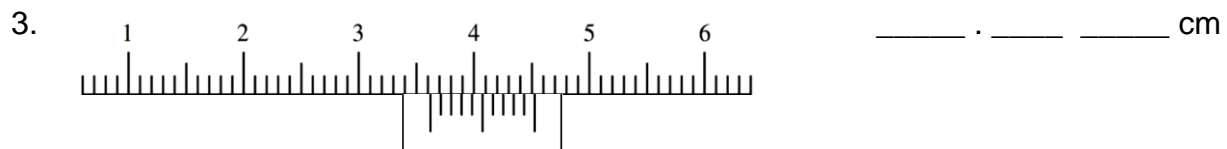
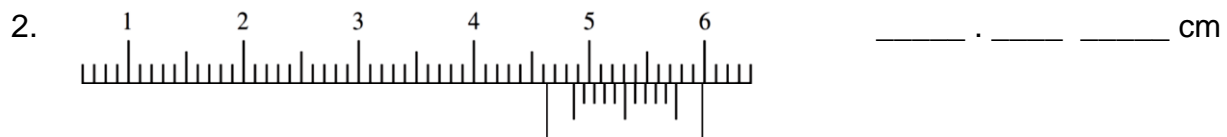
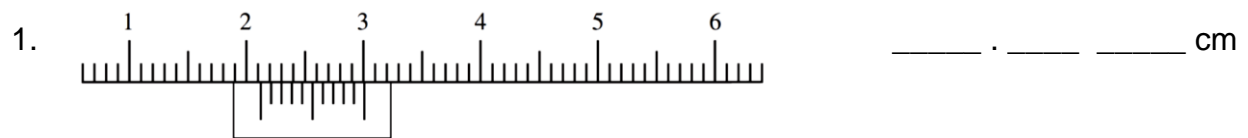

Micrometers

Micrometers are another tool that can be used for making small, precise lengths. In fact, micrometers can make even smaller and more precise measurements than a vernier caliper can! Micrometers often measure things like the thickness of the walls of a pipe, nuts and bolts, washers, and nails. While vernier calipers can measure accurately to the nearest tenth of a millimetre (0.1 mm), a micrometer can measure to the nearest hundredth of a millimetre (0.01 mm).

The micrometer on the top right shows the standard design of a micrometer. The areas that we will concentrate on are the sleeve or barrel and the thimble. The thimble is the moving scale on a micrometer.



Imperial micrometer

As the jaws open and the space between the anvil and the spindle gets larger, the thimble turns and goes further down the barrel. This top micrometer is calibrated in imperial units whereas the second photo shows an SI or metric micrometer. All the parts are the same, just the scales are different.



Metric micrometer



Metric micrometer's barrel and thimble

This last photo shows an enlargement of the barrel and thimble of the SI or metric micrometer. This is the type of photo or diagram that you will be reading the measurements from.

Reading SI or Metric Micrometers

When an object is placed in the jaws of a micrometer between the anvil and the spindle, the thimble is turned in order to make the object, like a pencil, fit. As the thimble is turned it moves to the right (in the diagram below) and the length on the barrel increases.

To read any length, first look at the top of the barrel reading. This scale is in millimetres. Simply count from the zero to where the thimble cuts across the barrel. In this example, the thimble crosses the barrel just past 8 mm. So this is our starting reading.

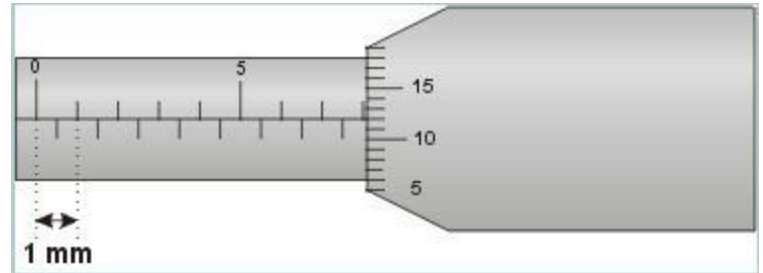

Now it is necessary to read the thimble on the micrometer. The thimble reading is made where the line from the barrel crosses the thimble. In this diagram, the thimble reads 12. However, this is NOT 12 mm but 0.12 mm. Now the readings are added together to get the final reading:

$$8 \text{ mm} + 0.12 \text{ mm} = 8.12 \text{ mm}$$

Notice on the bottom of the scale in the barrel that there are also divisions. These are half millimetre divisions. They are used when the thimble is only partly turned between whole millimetre marks as shown in the second micrometer below:

While the top of the scale on the barrel is still showing 8 mm, there is a tick mark now showing on the bottom of the scale before the thimble. If this is the situation, you must add 0.5 mm to the top reading before reading the thimble. So this reading would be:

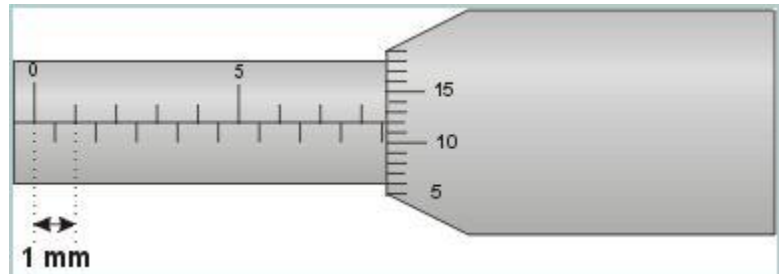

$$8 \text{ mm} + 0.5 \text{ mm} + 0.12 \text{ mm} = 8.62 \text{ mm}$$

While measuring with a vernier caliper, there might be some room for error depending on which lines match the best, with the micrometer, there is only one right answer. Therefore, micrometers are much more precise and accurate than vernier caliper are.

Other sites that will help you if you are having any trouble are the following:

<http://members.shaw.ca/ron.blond/Micrometer.APPLET/>

<http://www.upscale.utoronto.ca/PVB/Harrison/Micrometer/Micrometer.html>

Now try these micrometers and write their measurements down beside each one.

ASSIGNMENT 11 – MICROMETERS

1.

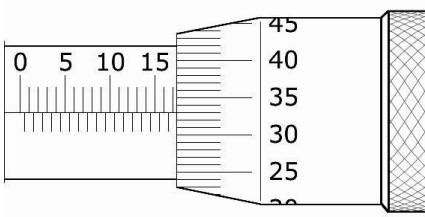

2.

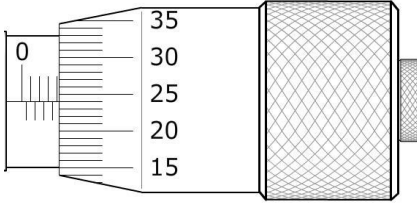

3.

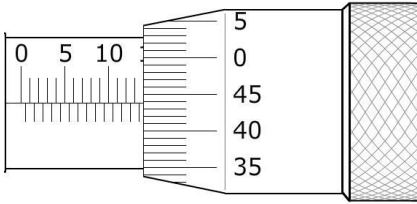

4.

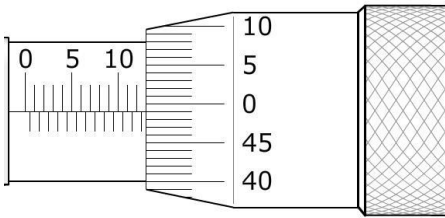

5.

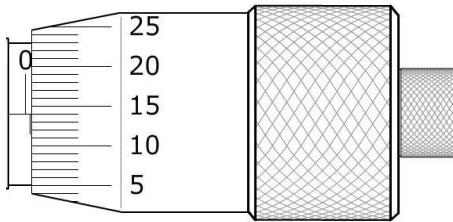

6.

